





# ASSEMBLY INSTRUCTION

MODEL: DM22084- PT

| NO | PARTS LIST  | QTY  |
|----|---|------|
| 1  | TABLE TOP<br>      | 1PC  |
| 2  | SIDE LEG<br>       | 2PCS |
| 3  | TOP SUPPORT<br>    | 2PCS |
| 4  | CENTER SUPPORT<br> | 1PC  |
| 5  | SUPPORT<br>        | 2PCS |

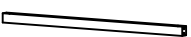
| NO | HARDWARE LIST   | QTY   |
|----|---|-------|
| A  |  JCBC M6 x 70mm      | 8PCS  |
| B  |  JCBC M6 x 85mm      | 4PCS  |
| C  |  SPRING WASHER       | 12PCS |
| D  |  FLAT WASHER 19mm    | 12PCS |
| E  |  CSK SCREW M4 x 32mm | 8PCS  |
| F  |  M4 ALLEN KEY        | 1PC   |
| G  |  BARREL NUT 100mm    | 2PCS  |

## STEP 1

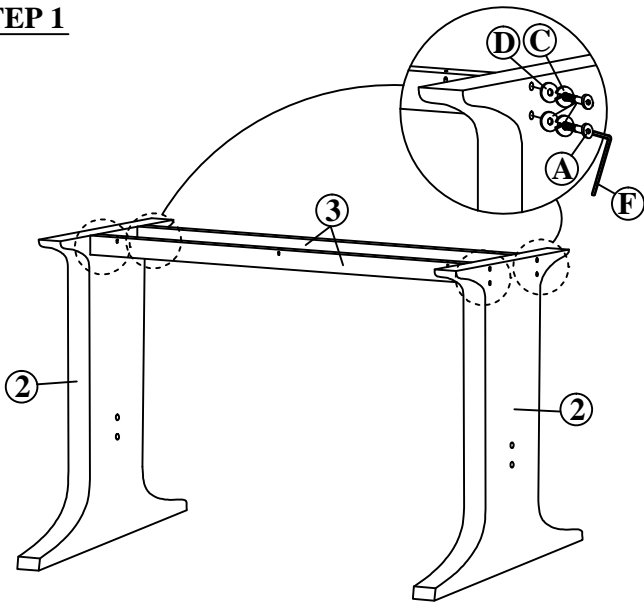

## STEP 2

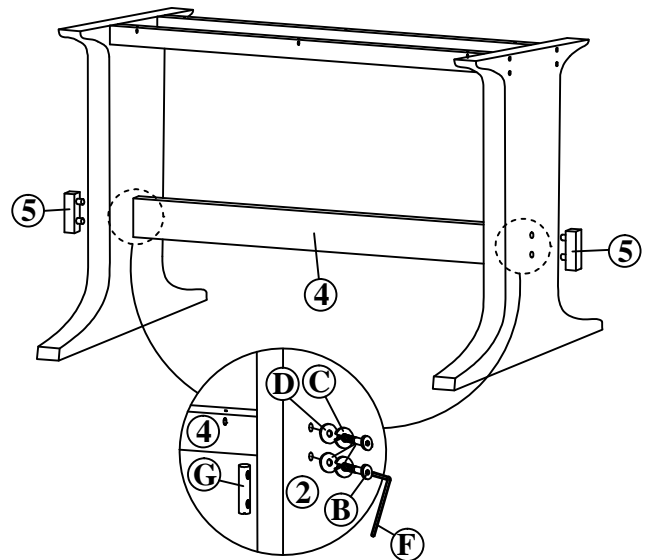

## STEP 3

